

## Tiger Super Automatic Espresso Machine

ITEM#

PROJECT

DATE



### Model Tiger M Series

Dimensions: 23.8"H x 15.8"W x 17.1"D  
(60.5 cm H x 40.1 cm W x 43.4 cm D)

### Features

#### Tiger M Series

- Up to 180 shots per hour from less than 16" of counter space.
- Intelligent modular brewing chamber adjusts espresso.
- Simulates Barista tamping and polishing motion to provide uniform extraction.
- One (M-1) or two-grinder (M-2) models available for regular and decaf or other specialty beans.
- Hoppers hold 3 lbs (M-1) or 1.75 lbs (M-2) of fresh beans.
- Adjusts for 3 to 5.7 inch cup clearance.
- Pod brewing option standard on all models.
- Intuitive operational design. Easy to use control pad guides user through steps for making drinks.
- Easy daily cleaning.
- Innovative milk delivery system does not inject steam or water to dilute the foam so customers enjoy a full, rich flavor experience.
- Internal milk storage. Self-contained chiller system holds 1 gallon (4 litres) of your choice of milk.

For current specification sheets and other information, go to [www.bunn.com](http://www.bunn.com).

### Related Products

#### Espresso Water Quality System

EQHP-ESP

Product No. :39000.0008

#### Replacement Cartridge

EQHP-ESPCRTG

Product No.: 39000.1008



#### Urnex® Cafiza™ Cleaning Tablets

Product No.: 36000.1189 (100 count)

Product No.: 36000.1188 (12/case)

#### Urnex® Rinza™

Milk Frother Cleaner

Product No.: 39265.0000 (each)

Product No.: 39265.0001 (6/case)

#### Model

Tiger M-1

Tiger M-2

#### Agency Listing



## Dimensions & Specifications

Model	Product #	Volts	Amps	Tank Heater Watts	Total Watts	Capacity	Cubic Measure	Shipping Weight	Cord Attached
Tiger M-1*	35800.0000	120	16	1700	1850	180 shots/hr	3.7 ft <sup>3</sup>	86 lbs	Yes
Tiger M-1*	35800.0001	208	11.5	2000	2400	180 shots/hr	3.7 ft <sup>3</sup>	86 lbs	Yes/ No Plug
		240	12.9	2700	3100				
Tiger M-2**	35800.0002	120	16	1700	1850	180 shots/hr	3.7 ft <sup>3</sup>	88 lbs	Yes
Tiger M-2**	35800.0003	208	11.5	2000	2400	180 shots/hr	3.7 ft <sup>3</sup>	88 lbs	Yes/ No Plug
		240	12.9	2700	3100				

\*Single hopper and grinder. \*\*Model with two hoppers and grinders.

Model includes: Machine, water filtration system, installation and 2-year preventative maintenance.

Electrical: Model requires 2-wire grounded service rated 120/208V, single phase, 50/60 Hz.

Plumbing: 20-100 psi (138 - 690 kPa). Machine supplied with 1/4" male flare fitting. All machines are supplied with a waste water hose and must be connected to a drain.

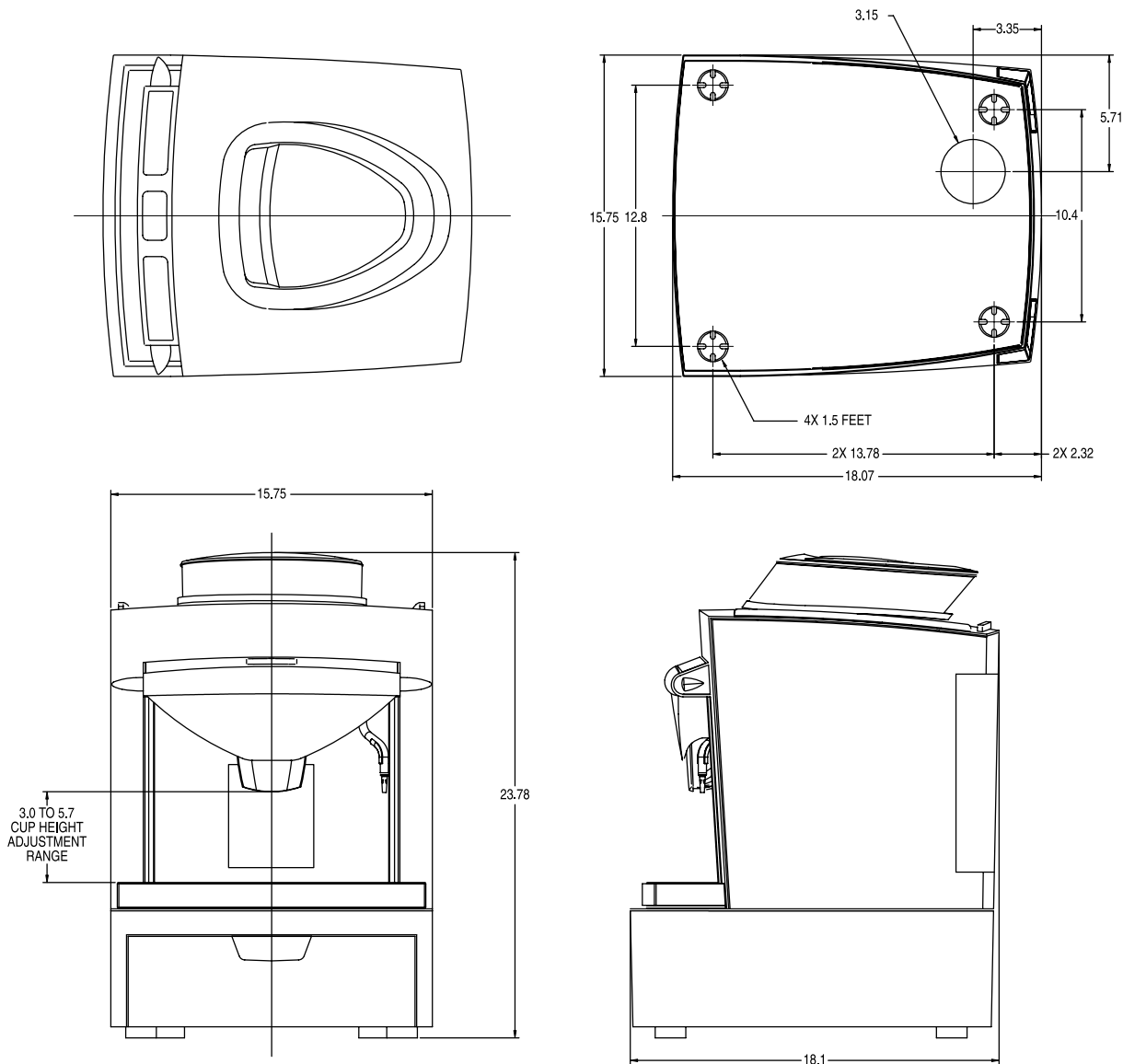

BUNN Corporation - 1400 Stevenson Drive Springfield, Illinois 62703 • 800-637-8606 • 217-529-6601 • Fax 217-529-6644 • www.bunn.com

BUNN® practices continuous product research and improvement. We reserve the right to change specifications and product design without notice. Such revisions do not entitle the buyer to corresponding changes, improvements, additions or replacements for previously purchased equipment.

All dimensions shown in inches. Bunn Corporation owns all copyrights relating to materials in this publication. Please contact Bunn Corporation to request permission to reproduce any portion of this publication.