

Features

Automatic CDBC Coffee Brewers

- Larger 200 oz. tank provides back-to-back brewing capacity.
- Improved brewing system has better temperature accuracy.
- Adjusts automatically to varying water pressure.
- Quicker install saves up to 30 minutes. Pot level, cold brew lock-out and tank temperature set easily from advanced touch pad on front of machine.
- Faster field repairs and quick problem diagnostics by phone; built-in electronic sensors feed back information on brewer malfunctions.
- Insures coffee brew quality with cold brew lock out capability.
- SplashGard® funnel deflects hot liquids away from the hand.
- Coffee extraction controlled with pre-infusion, Pulse Brew™ and digital temperature control.
- Pourover feature.



*Model CDBCFCP
(2 top warmers)
(decanters not included)*

Dimensions: 18.9" H x 8.25" W x 17.8" D

ITEM#

PROJECT

DATE

Line

CDBCFCP15

For current specification sheets and other information, go to www.bunnomatic.com.

BUNN recommends the use of our Easy Clear® Water Quality Systems and BUNN paper filters to assure perfect taste.

Easy Clear® EQ-17-TL
Product No. : 30200.1000
Dimensions:
12⁷/₁₆" H x 2¹/₂" W x 3" D



Easy Clear® ED-17-TL
Product No. : 30201.1001
Dimensions: 8¹/₄" H x 2⁵/₁₆" Dia.

Paper Filter Pack
Product No. : 20115.0000
Packed per case: 1,000
Dimensions: 4¹/₄" Base x 2³/₄" Sidewall



Easy Pour® black decanter
Product No. : 06100.0101
Quantity: 1 (also packaged in quantities of 2, 3, 6, 12, & 24)



1GPR SS Portable Server on an RWS1 Warmer
1GPR Product No. : 12487.0001*
RWS1 Product No. : 12203.0010
**Also available with side handles or black decor.*



BUNN® practices continuous product research and improvement. We reserve the right to change specifications and product design without notice. Such revisions do not entitle the buyer to corresponding changes, improvements, additions or replacements for previously purchased equipment.

BUNN®

Corporate Offices
1400 Stevenson Drive
Springfield, Illinois 62703
Phone
800-637-8606
217-529-6601
Fax
217-529-6644
Technical Services
800-286-6070
Internet
<http://www.bunnomatic.com>

Western Regional Office
16431 Carmenita Road,
Cerritos, California 90701
Phone
562-926-0764
Fax
562-926-0858

Canadian Office
280 Industrial Parkway South
Aurora, Ontario, L4G 3T9
Phone
905-841-2866
Fax
905-841-2775

Patents
Apply



Dimensions & Specifications

Model	Product #	Volts	Amps	Tank Heater Watts	Total Watts	Brewing Capacity	Cu. Ft.	Shipping Weight	Cord Attached
CDBCFP15 (2 top)	28800.0300	120	15	1425	1800	4.5 gal./hr.	6.3	30 lbs. (13.6 kg)	Yes
CDBCFP15 (2 top)*	28800.0303	120	15	1425	1800	4.5 gal./hr.	6.3	30 lbs. (13.6 kg)	Yes

*Model has a stainless steel funnel.

Electrical: 120 volt, 15 amp. models require 2-wires plus ground service rated 120V, single phase, 60 Hz.

Plumbing: 20-90 psi (138-621 kPa). Machines supplied with 1/4" male flare fitting. Twin models supplied with 3/8" male flare fitting.

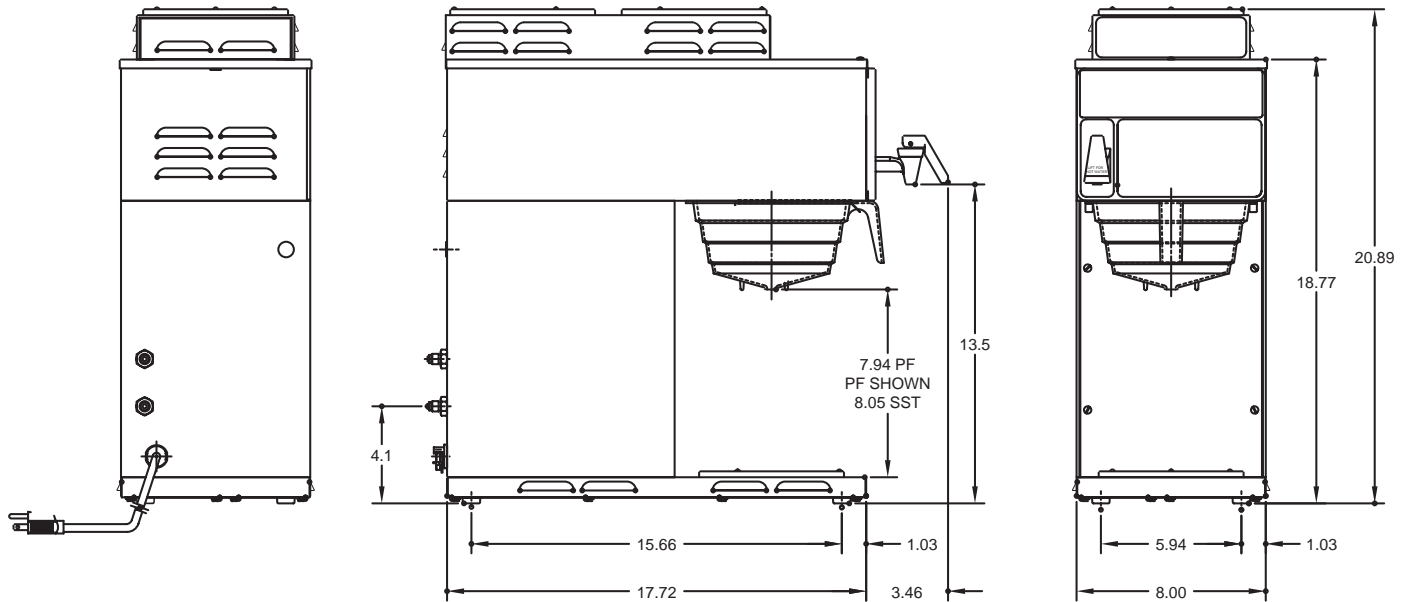
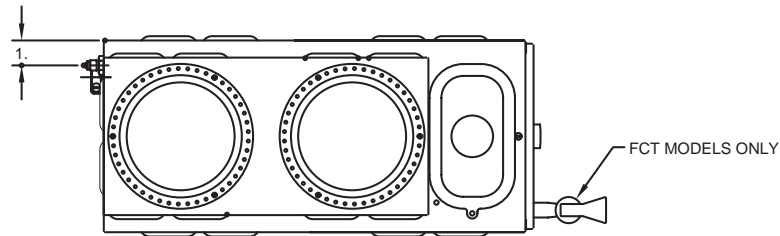

(POUR-OVER W/1LWR/2UPR WARMERS)