

Volume Coffee At Your Fingertips...

Complete mobility of hot, freshly-brewed coffee for any size banquet or catered event can now be accomplished with the CBS-61H30 brewing system.

Brew directly into 3.0 gallon LUXUS® thermal dispensers and expand your coffee service beyond the lobby and restaurant to any remote location.

System features allow for large volumes of coffee to be brewed without degrading the coffee integrity, without additional heat and without limit to location. FETCO® brewers ensures the safety and integrity of each brew and uses technological advances in order to hold a constant water temperature during 100% of brew cycle, maintain sprayover volume consistency and resist lime buildup inside dispense system.

The LUXUS® Thermal Dispenser

Provides the ultimate in hot and cold beverage dispensing. Totally portable, they require no electric power to maintain temperature. You can prepare them ahead of time. Once filled and capped, they go anywhere. Ready to act as your remote dispensing station wherever needed. Indoors, outdoors, on different floors, or placed throughout a restaurant, hotel or office for hours of fresh hot coffee service. LUXUS® thermal dispensers can be staff operated or used as a self-service system.



TPD - 3.0 Gallon LUXUS® Thermal Dispenser



CBS-61H30 in Stainless Steel Finish and with 3.0 Gallon LUXUS® Thermal Dispenser

CBS-61H30

Standard Features:

- 3.0 Gallon Thermal, All Stainless Steel Lined Beverage Dispenser
- Stainless Steel, Gourmet Size Brew Basket
- Brew Basket Double Safety Lock
- Open Type, Leak Free Dispense System
- Fully Automatic With Electronic Temperature Control
- Mercury Type Power Contactor
- Durable 18 Ga. Stainless Steel Construction
- Total Serviceability From The Front
- Hot Water Faucet

Dimensions & Specifications

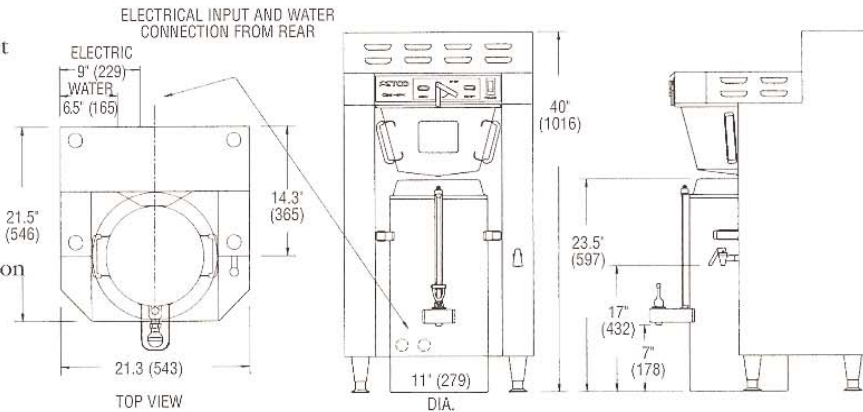

Water Requirements: 20-75 psig, 1-1/2 gpm flow rate. Water inlet is 3/8" Male Flare Fitting

Optional Features:

- Half Batch Brewing Capability
- Steam Heated Version With Inlet Strainer And Steam Trap Mounted On The Back Side
- Custom And Export Voltage

Accessories:

- 3.0 Gallon Luxus® Thermal Dispensers
- Drip Tray

Standard Electrical Configurations & Brewing Efficiency

3.0 gallons per batch

Model	Heater Configuration	Voltage Connection	Phase	Wires	KW	Maximum Amp Draw	Batches per Hour	
							Cold Water	Hot Water
CBS-61H (-1)	2 x 3000 watt	120/208	1 ph.	3 + ground	4.6	22.1	3.7	8.6
		120/220	1 ph.	3 + ground	5.2	23.4	4.3	9.0
		120/240	1 ph.	3 + ground	6.1	25.5	5.0	9.0
CBS-61H (-2)	2 x 4000 watt	120/208	1 ph.	3 + ground	6.1	29.3	5.0	9.0
		120/220	1 ph.	3 + ground	6.8	31.0	5.8	9.0
		120/240	1 ph.	3 + ground	8.1	33.8	6.6	9.0
CBS-61H (-3)	3 x 3000 watt	120/208	3 ph.	4 + ground	6.9	19.5	5.6	9.0
		120/220	3 ph.	4 + ground	7.7	20.6	6.5	9.0
		120/240	3 ph.	4 + ground	9.1	22.4	7.4	9.0
CBS-61H (-4)	3 x 4000 watt	120/208	3 ph.	4 + ground	9.1	25.8	7.4	9.0
		120/220	3 ph.	4 + ground	10.3	27.3	8.6	9.0
		120/240	3 ph.	4 + ground	12.1	29.7	9.0	9.0

Weights & Capacities

MODEL	HEIGHT	WIDTH	DEPTH	BREWER EMPTY	BREWER FILLED	DISPENSER EMPTY	DISPENSER FILLED	BREWER & DISP FILLED	WATER TANK	DISPENSER	SHIPPING WEIGHT	CU. FT. (2 BOXES)	CU. FT. STEAM
CBS 61H30	in/mm	in/mm	in/mm	lbs/kg	lbs/kg	lbs/kg	lbs/kg	lbs/kg	gal/l	gal/l	lbs/kg	cu ft/cu dec	cu ft/cu dec
CBS 61H30	40/1016	21.3/543	21.5/546	111/50	177/79.7	18/8.1	22.5/19.1	220/99	8/30.2	3/11.3	135/60.8	17.2/487	20.6/583

Patents & Approvals:

U.S. Pat. Nos. 5,000,082; 5,331,885. Other patents pending.

This product is approved by one or more of the following marks:



FETCO® Corporation is a proud and active member of these organizations:



FETCO
CORPORATION

Food Equipment Technologies Company
640 Heathrow Drive, Lincolnshire, IL 60069 USA
Phone: 847.821.1177 800-FETCO 99 Fax: 847.821.1178
Internet: www.fetco.com E-mail: sales@fetco.com

FETCO & LUXUS are both trademarks or tradenames of Food Equipment Technologies Company. All other trademarks or tradenames are trademarks or tradenames of their respective owners.